

Designed for larger commercial and industrial applications, this pump is ideal for trouble-free pumping of effluent, wash-down and stormwater in commercial and industrial applications, particularly where solids and stringy material need to be handled.

Units are fitted with a powerful single-phase or 3-phase motor incorporating an EasyFit plug-in cable for simple disconnection and replacement.

GPV65-180 single-phase unit comes with an automatic float switch.



### Dimensions (all measurements mm)

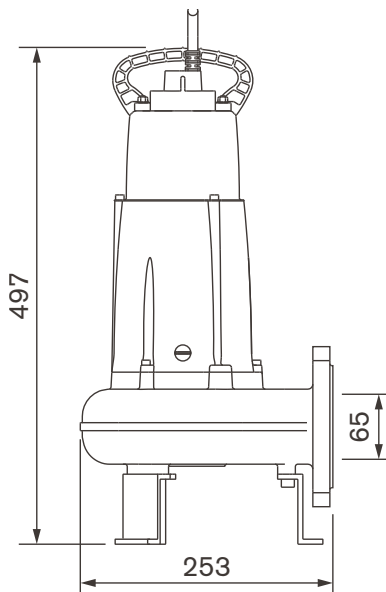

## GP Series Submersible Sump Pumps

GPV65-180 single-phase

GPV65-200 3-phase

### Technical data

Model GPV	65-180	65-200
Outlet (mm)	65 DIN flange	
Max flow rate (L/s)	15.4	
Max head (m)	8.1	
Max liquid temp (°C)	40	
Ø Solids (mm)	60	
Power (kW)	1.8	2
Current (A)	11.6	4.6
Voltage (V)	240	415
Speed (RPM)	2900	
Casing	Cast iron	
Impeller	Polyamide vortex	
Motor housing	Stainless steel	
Protection	IP68	
Cable details	10 m length, H07RN8-F	
Mounting	Free-standing or guide rails	
Weight (kg)	24	

### Performance curve

