

Ideal for pumping effluent, stormwater run-off and contaminated drainage water in light commercial applications, particularly where there is the likelihood of solids or stringy material.



Technical data

Outlet (mm)	50 BSP
Max flow rate (L/s)	12.5
Max head (m)	14
Max liquid temp (°C)	40
Ø Solids (mm)	50
Power (kW)	1.1
Current (A)	7.8
Voltage (V)	240
Speed (RPM)	2900
Casing	Epoxy electro coated cast iron
Impeller	Stainless open-type
Motor housing	Stainless steel
Protection	IP68
Cable details	10 m length, H07RN-F
Mounting	Free-standing only
Weight (kg)	18.8

Dimensions (all measurements mm)

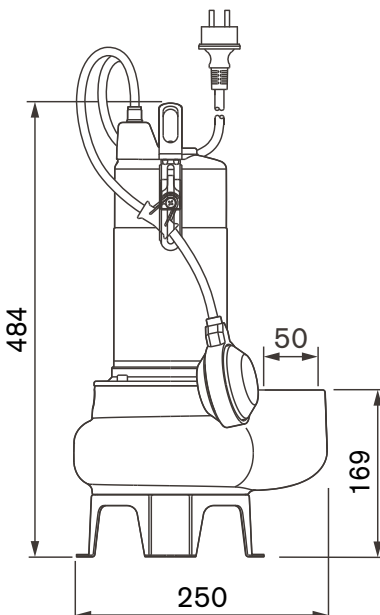

Performance curve

