

Ideal for pumping sewage, wastewater and stormwater drainage.

Features

- non-clog single channel impeller
- rugged cast iron construction, with stainless steel fasteners
- double mechanical seal in oil chamber.



Technical data

Model GPV	150-550	150-750
Outlet (mm)	100/150 Table D flange bend	
Max flow rate (L/s)	59	66.5
Max head (m)	21	25
Max liquid temperature (°C)	40	
ø Solids (mm)	75	
Power (kW)	5.5	7.5
Current (A)	12.7	16.9
Voltage (V)	415	
Speed (RPM)	1440	
Casing	Cast iron	
Impeller	Cast iron vortex	
Motor housing	Cast iron	
Protection	IP58	
Cable details	10 m length, H07 RN-F	
Mounting	Freestanding or guide rail mount	
Weight (kg)	127	132

Dimensions (all measurements mm)

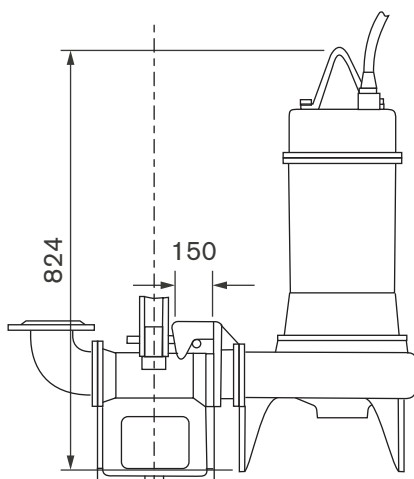

Performance curve

